

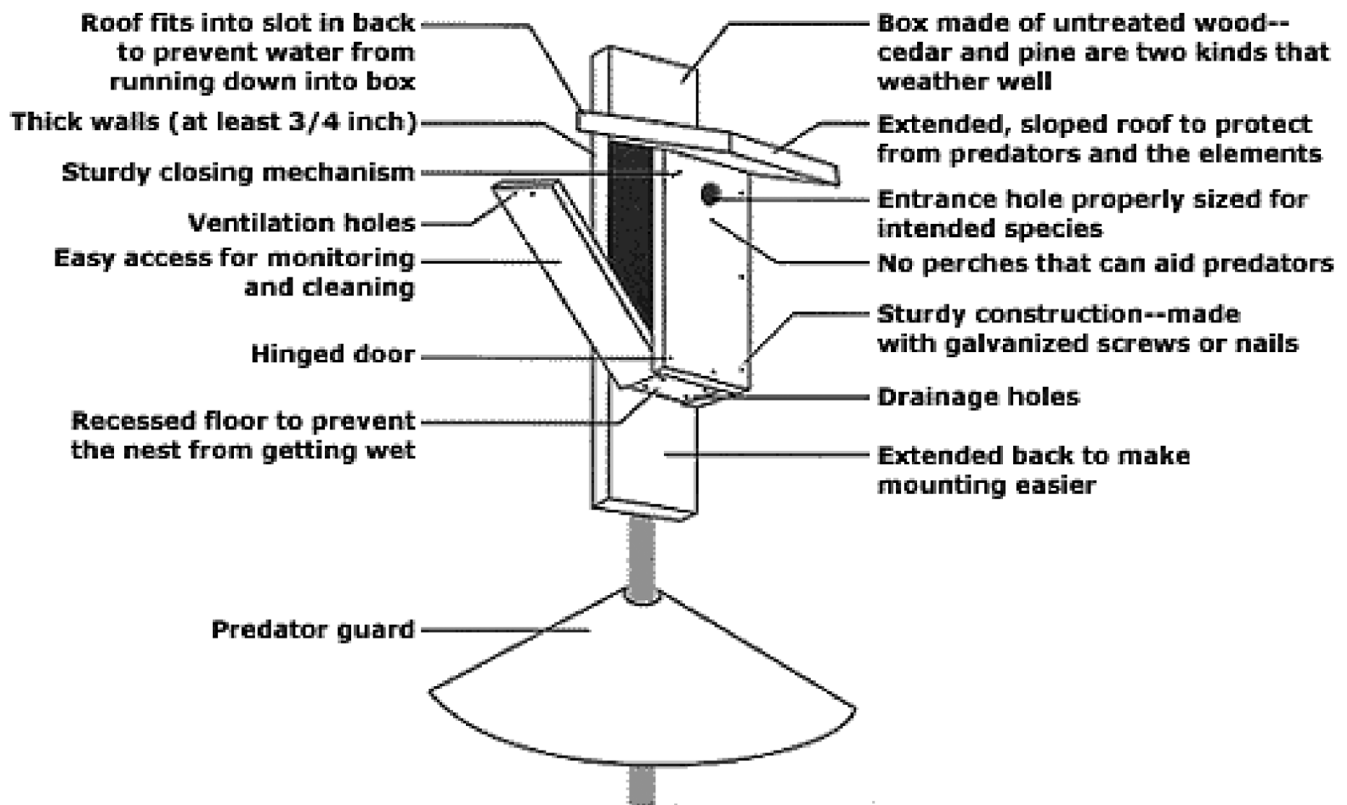

Features of a good birdhouse

Birdhouses (also known as nest boxes) come in many shapes and sizes, and choosing which nest box to build or buy can be confusing. Whether you plan to build or buy a nest box, it should contain the features listed below. Make sure that it is well constructed and made with the birds and nest-box monitoring in mind. It should be durable, easy to check, and clean.



Quick Checklist

- ✓ UNTREATED WOOD (PINE, CEDAR, OR FIR)
- ✓ THICK WALLS (AT LEAST 3/4 INCHES)
- ✓ EXTENDED, SLOPED ROOF
- ✓ ROUGH OR GROOVED INTERIOR WALLS
- ✓ RECESSED FLOOR
- ✓ DRAINAGE HOLES
- ✓ VENTILATION HOLES
- ✓ EASY ACCESS FOR MONITORING AND CLEANING
- ✓ STURDY CONSTRUCTION
- ✓ NO OUTSIDE PERCHES

Please visit our Resource Center at www.nestinginfo.org
for additional information on nest box requirements.